

- EN Mounting instructions
- DE Montageanleitung
- FR Consignes d'installation
- NL Montagevoorschrift
- ES Instrucciones de montaje
- IT Istruzioni di montaggio
- PT Manual de montagem
- EL Οδηγίες συναρμολόγησης
- SV Montageföreskrifter
- PL Instrukcja montażu
- RU Инструкция по сборке и установке
- CZE Návod k montáži
- SK Návod na montáž
- HU Szerelési előírás
- TR Montaj kılavuzu
- RO Instrucțiuni de montaj
- UK Вказівки по монтажі
- BG Инструкции за монтаж
- JA 設置の説明書
- ZH 装配说明

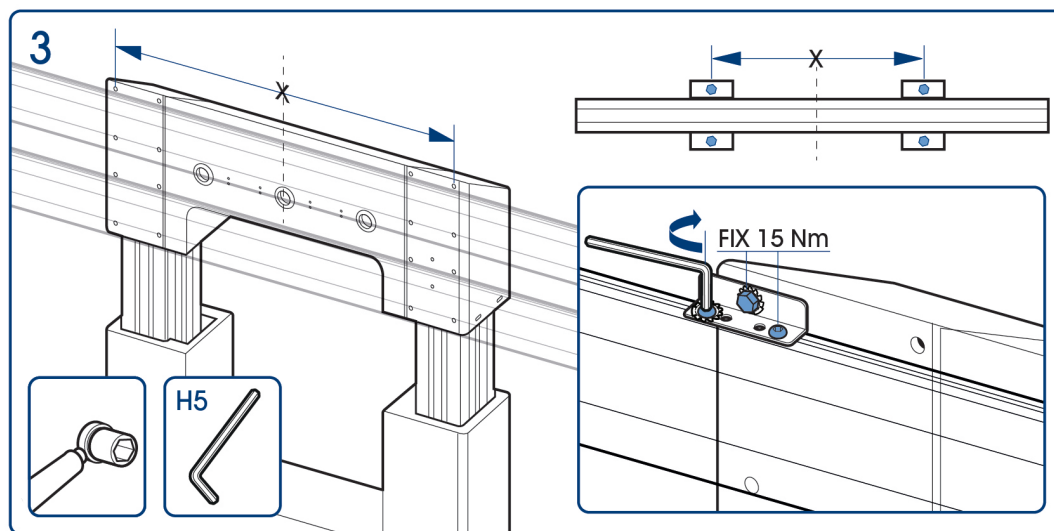

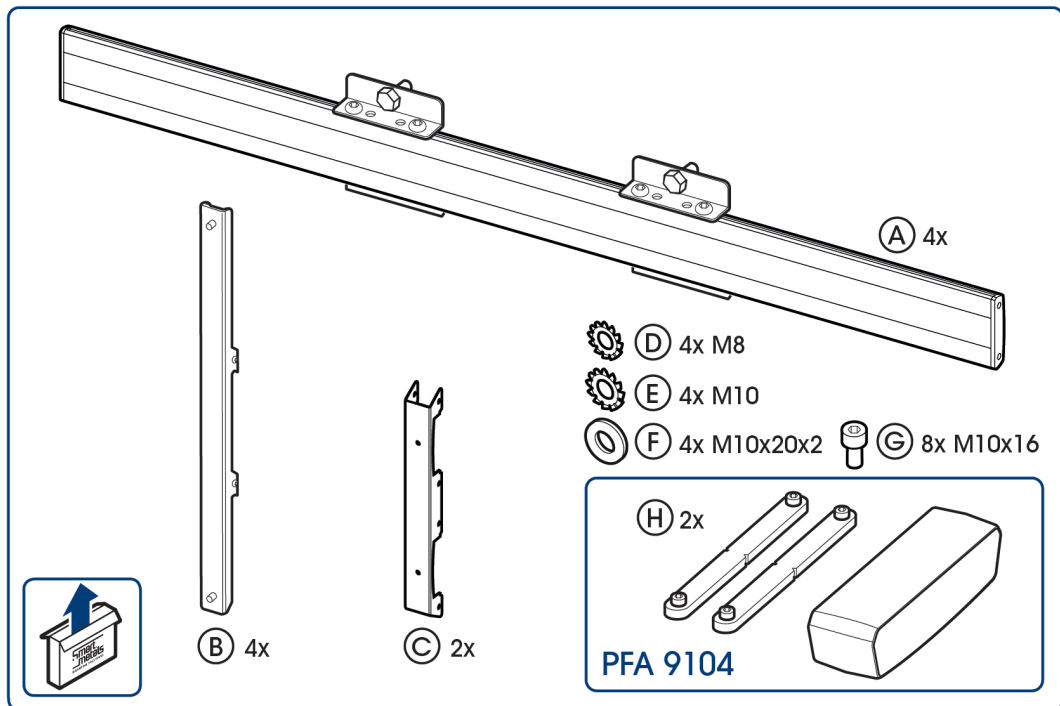
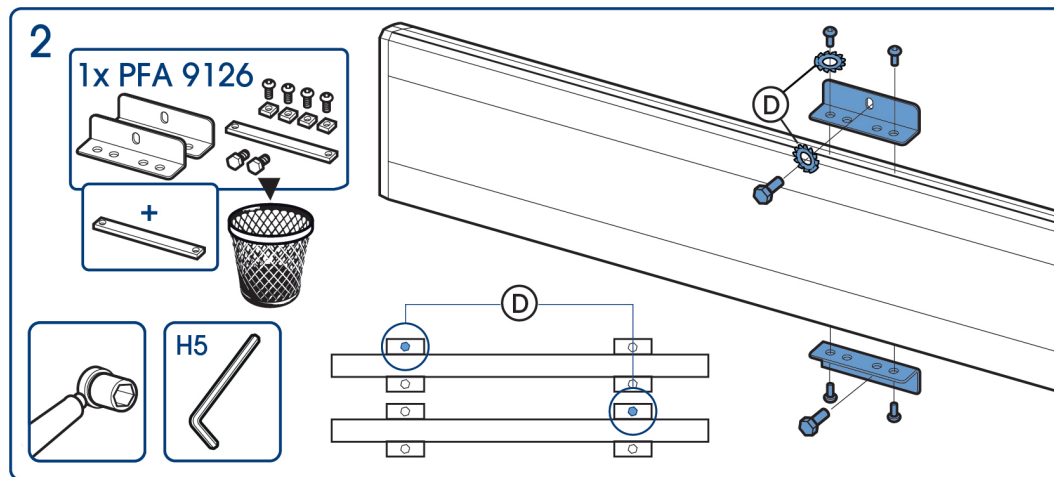
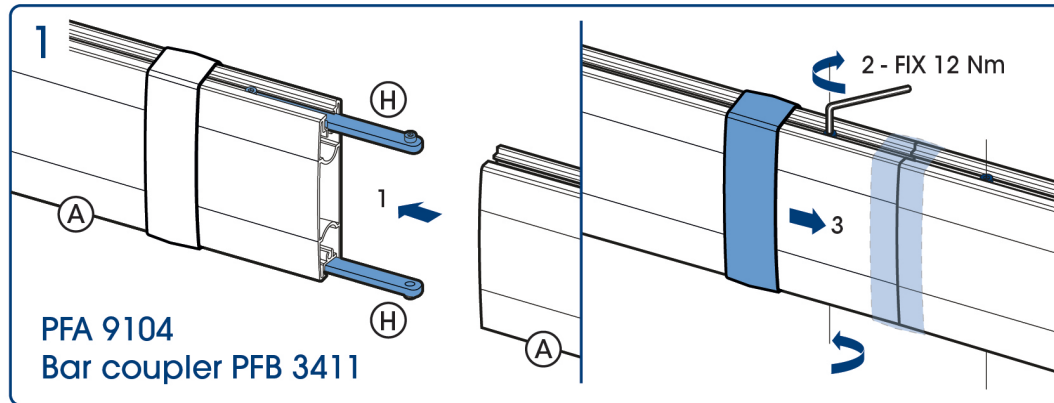
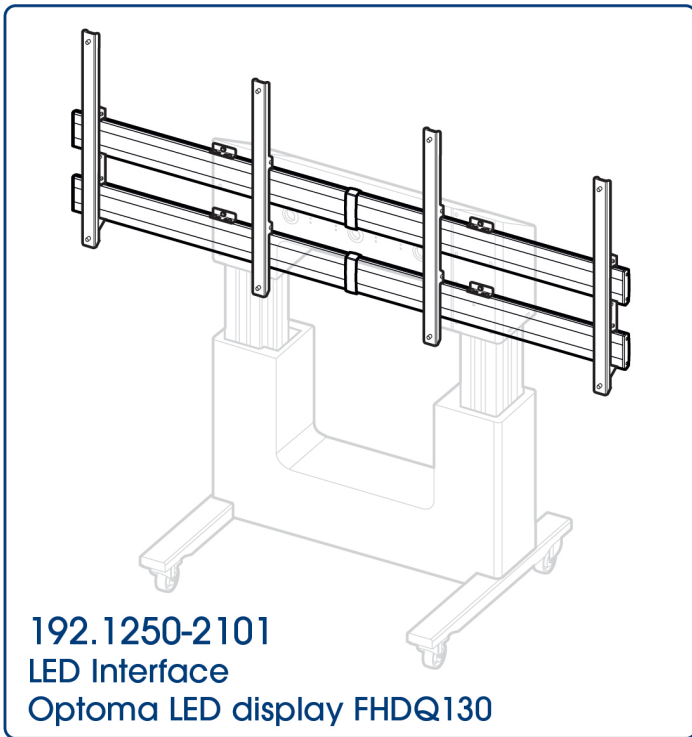
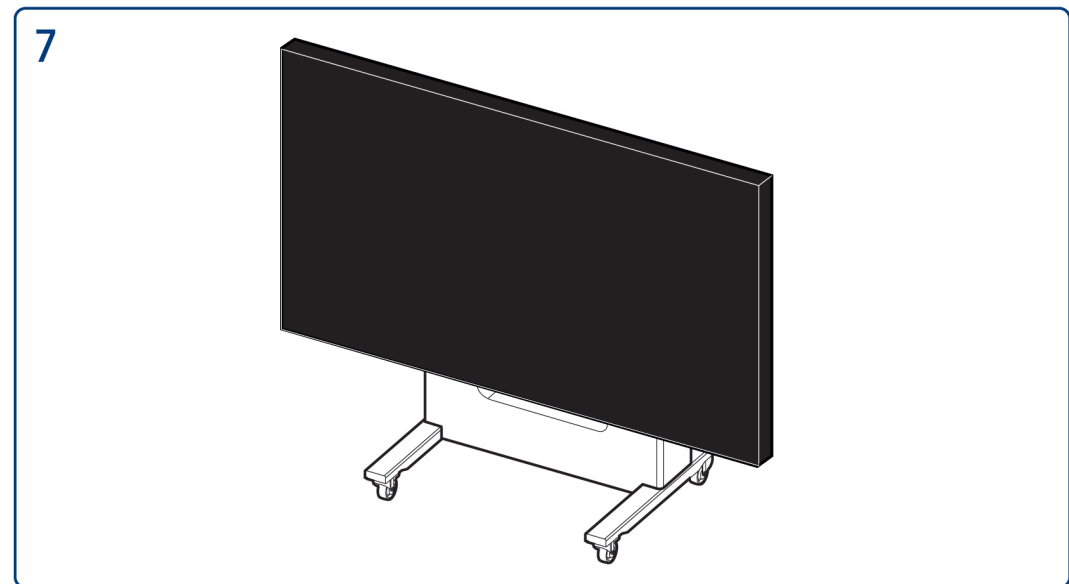
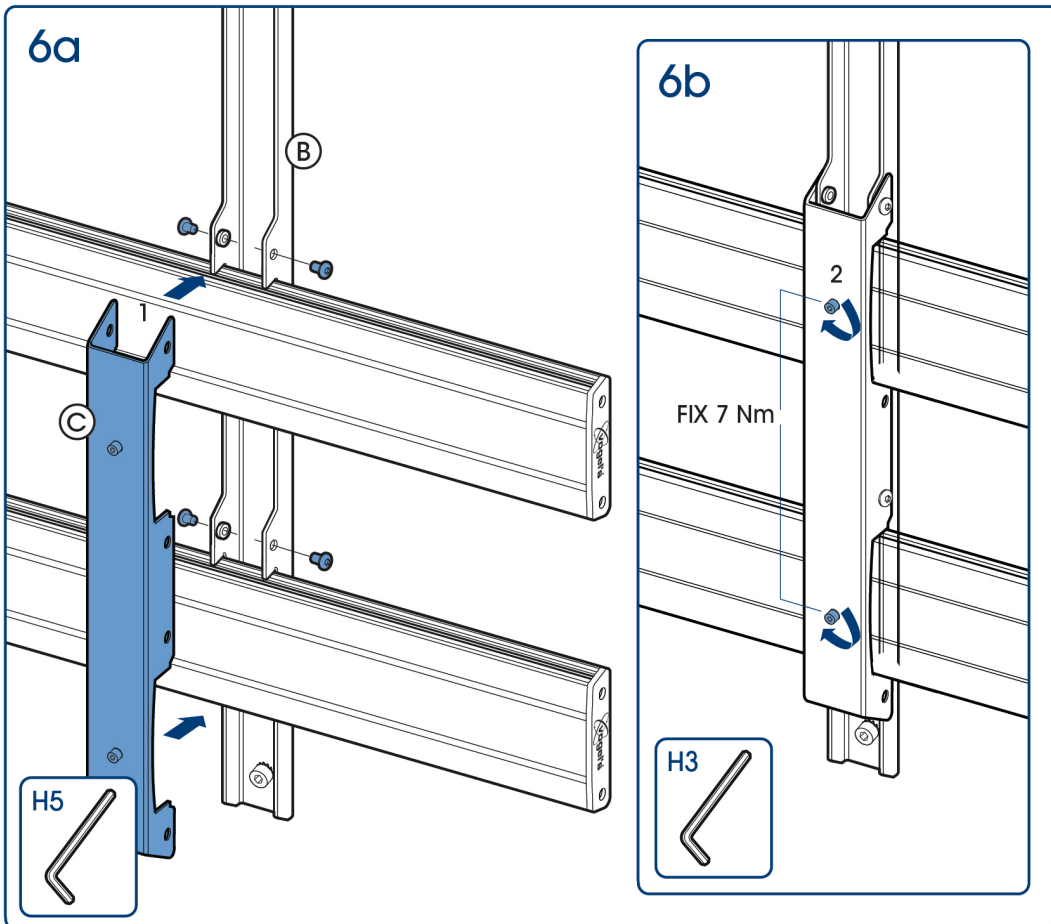
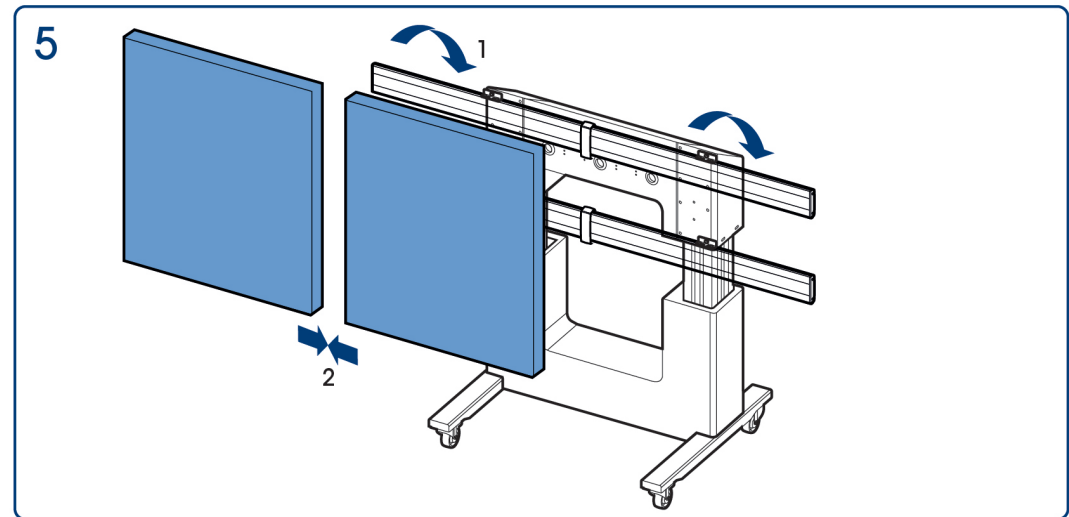
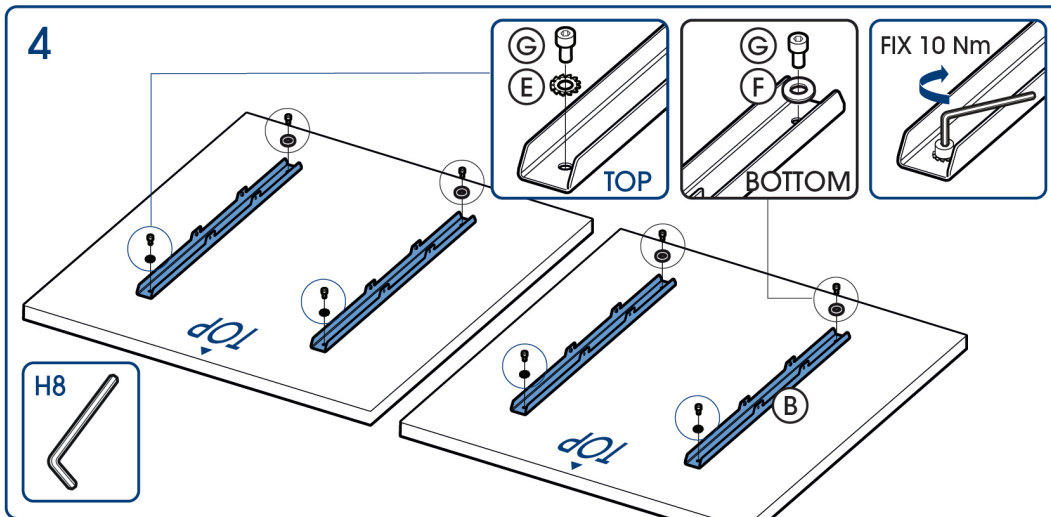

- (GB) Subject to printing errors and technical amendments.  
 (NL) Drukfouten en technische wijzigingen voorbehouden.  
 (F) Sous réserve de fautes d'impression et de modifications techniques.  
 (D) Für Druckfehler übernehmen wir keine Verantwortung. Technische Änderungen vorbehalten.  
 (E) Reservados errores de imprenta y sujete a modificaciones.  
 (I) Con riserva di modifiche tecniche e di eventuali errori di stampa.  
 (P) Reserva-se a ocorrência de gralhas e de modificações técnicas.  
 (H) Nyomdahibák és technikai változtatások joga fenntartva.  
 (PL) Zastrzega się możliwość występowania błędów drukarskich i zmian technicznych.  
 (RUS) Возможны ошибки при печати и технические модификации.

## DISCLAIMER

SmartMetals Mounting Solutions B.V. and its affiliated corporations and subsidiaries (collective "SmartMetals"), intend to make this manual accurate and complete. However, SmartMetals makes no claim that the information contained herein covers all details, conditions or variations, nor does it provide for every possible contingency in connection with the installation or use of this product. The information contained in this document is subject to change without notice or obligation of any kind. SmartMetals makes no representation of warranty, expressed or implied, regarding the information contained herein. SmartMetals assumes no responsibility for accuracy, completeness or sufficiency of the information contained in this document.  
All rights reserved.

## DEFINITIONS

**MOUNTING SYSTEM:** A MOUNTING SYSTEM is the primary SmartMetals product to which an accessory and/or equipment is attached.

**ACCESSORY:** AN ACCESSORY is the secondary SmartMetals product which is attached to a primary SmartMetals product, and may have equipment attached or setting on it.

**EQUIPMENT:** With EQUIPMENT we mean an audiovisual item designed to be attached or resting on an accessory or mounting system such as a video camera, CPU, screen, display, projector, etc.

**INSTALLER:** Wherever in this document an installer is mentioned, a certified installer is meant.

**WARNING:** A WARNING alerts you to the possibility of serious injury or death if you do not follow the instructions.

**CAUTION:** A CAUTION alerts you to the possibility of damage or destruction of equipment if you do not follow the corresponding instructions.

## IMPORTANT SAFETY INSTRUCTIONS

**WARNING:** Failure to read, thoroughly understand, and follow all instructions can result in serious personal injury, damage to equipment, or voiding of factory warranty! It is the certified installer's responsibility to make sure all mounting systems/accessories are properly assembled and installed using the instructions provided.

**DANGER:** To reduce the risk of electric shock: Always unplug this furnishing from the electrical outlet before cleaning.

**WARNING:** To reduce the risk of burns, electric shock, or injury to persons:

1. Unplug from outlet before putting on or taking off parts.
2. Close supervision is necessary when this furnishing is being used by, or near, children, invalids, or disabled persons.
3. Use this furnishing only for its intended use as directed in these instructions. Do not use attachments not recommended by the

manufacturer.

4. Never operate this furnishing if it has a damaged cord or plug, if it is not working properly, if it has been dropped or damaged, or dropped into water. Return the furnishing to a service center for examination and repair.
5. Keep the cord away from heated surfaces.
6. Never operate the furnishing with the air openings blocked. Keep the air openings free of lint, and the like.
7. Never drop or insert anything into any opening.
8. Do not use outdoors.
9. Do not operate where aerosol (spray) products are being used, or where oxygen is being administered.
10. To disconnect, turn all controls to the off position. Then remove plug from outlet.
11. Do not exceed duty cycle: Max. 10% or 2 minutes continuous use followed by 20 minutes not in use.

**WARNING:** Risk of Electric Shock! Connect this furnishing to a properly grounded outlet only.

**WARNING:** Failure to provide adequate structural strength for this mounting system can result in serious personal injury or damage to equipment!  
It is the certified installer's responsibility to make sure the structure to which this mounting system is attached can support five times the combined weight of all equipment. Reinforce the structure as required before installing the mounting system.

**WARNING:** Use this mounting system only for its intended use as described in these instructions. Do not use attachments not recommended by the manufacturer.

**WARNING:** Never operate this mounting system if it is damaged. Return the mounting system to a service center for examination and repair.

**WARNING:** RISK OF INJURY TO PERSONS! Do not place video equipment such as televisions or computer monitors on trolley legs.

**WARNING:** Exceeding the weight capacity can result in serious personal injury or damage to equipment! It is the certified installer's responsibility to make sure the combined weight of all accessories and equipment attached to the assembly up to (and including) the display does not exceed the maximum load. Use with heavier screens may result in instability causing tip over resulting in death or serious injury! The height adjustable feature will not function properly if the weight exceeds the given maximum load.

**WARNING:** RISK OF SERIOUS INJURY OR DEATH! Placing a remote control or toy on the trolley may encourage a child to climb onto the system causing the system to tip over onto the child. DO NOT place remote controls or toys on the lift!

**WARNING:** RISK OF SERIOUS INJURY OR DEATH! Relocating audio and/or video equipment to the system may result in the system collapsing or overturning onto a child. DO NOT relocate audio and/or video equipment to the system!

**CAUTION:** One end of the power cord must Remain accessible at all times!  
Do not block or impede access to plug at any time!

## SERVICING OF DOUBLE-INSULATED PRODUCTS

In a double-insulated product, two systems of insulation are provided instead of grounding. No grounding means is provided on a double-insulated product nor should a means for grounding be added to the product.  
Servicing a double-insulated product requires extreme care and knowledge of the system and should only be done by qualified service personnel.  
Replacement parts for a double-insulated product must be identical to those parts in the product. A double insulated product is marked with the words "DOUBLE INSULATION" or "DOUBLE INSULATED".

The symbol  may also be marked on the product.

**--SAVE THESE INSTRUCTIONS--**



**ENGLISH**  
**Mounting regulations**  
**WARNING**

A correct mounting is extremely important and this is not the responsibility of SmartMetals Mounting Solutions. Faulty mounting may result in injury to persons or damage to equipment. SmartMetals will not be responsible in any way if the product has been mounted incorrectly.

Mounting fittings are not included with the product for reasons of safety, since the properties and bearing strength of walls/ceilings are specific for each case. Suitable mounting fittings must be selected based on the material of the wall/ceiling.

Obtain advice from a specialist in the field or from a specialist shop concerning the choice of mounting fittings. It is the responsibility of the installer to ensure that the wall/ceiling can support at least four times the combined weight of the screen/projector and bracket. **The maximum load for this product is given in these mounting instructions.** The instructions for installation and use of the screen/projector must also be followed with respect to the location and attachment of the screen/projector.



**DEUTSCH**  
**Montagevorschriften**  
**WARNUNG**

Eine korrekte Montage ist von größter Bedeutung, und SmartMetals Mounting Solutions kann dafür keine Verantwortung übernehmen. Falsche Montage kann zu Personen- und Sachschaden führen. SmartMetals lehnt jede Art von Verantwortung ab, falls das Produkt falsch montiert wird.

Aus Sicherheitsgründen wird kein Montagematerial beigelegt, da Beschaffenheit und Tragkraft von Wand bzw. Decke unterschiedlich sind. Das Material für die Montage richtet sich nach dem Material von Wand bzw. Decke.

Bei der Wahl des geeigneten Montagematerials sollten Expertise oder Fachhandel herangezogen werden. Der Installateur trägt die Verantwortung dafür, dass die Wand bzw. Decke mindestens das vierfache Gesamtgewicht von Bildschirm/Projektor plus Halterung tragen kann. **Maximale Belastung für dieses Produkt steht in dieser Montageanleitung.** Bei der Montage müssen auch Installations- und Benutzungsvorschriften für den anzubringenden Bildschirm/Projektor beachtet werden.



**Règlements de montage**  
**AVERTISSEMENT**

Le montage doit impérativement être effectué de façon correcte et ne relève pas de la responsabilité de SmartMetals Mounting Solutions. Un mauvais montage peut occasionner des blessures corporelles et des dommages matériels. SmartMetals décline toute responsabilité en cas de montage incorrect de ses produits.

Pour des raisons de sécurité, aucun matériel de montage n'est livré avec les produits, car la nature et la capacité de soutien des murs/plafonds varient. Le matériel de montage est choisi en fonction de la composition du mur/plafond.

Pour vous aider à choisir le bon matériel, consultez un expert dans ce domaine ou un magasin spécialisé. Il est de la responsabilité de l'installateur de veiller à ce que le mur/plafond puisse supporter au moins quatre fois le poids total de l'écran/vidéo-projecteur et de son support. **Charge max. pour ce produit, d'après l'information dans ce guide d'installation.** Lors du montage, les instructions d'installation et d'utilisation de l'écran/vidéo-projecteur doivent elles aussi être suivies.



**NEREDLANDS**  
**Montage voorschriften**  
**WAARSCHUWING**

Correcte montage is van absoluut belang en valt niet binnen de aansprakelijkheid van SmartMetals Mounting Solutions. Onjuiste montage kan tot persoonlijk letsel en materiële schade leiden. SmartMetals kan niet, op wat voor manier dan ook, aansprakelijk worden gesteld indien dit product op onjuiste wijze is gemonteerd.

Om veiligheidsredenen wordt geen Montagemateriaal bijgevoegd, gezien het feit dat de staat en het draagvermogen van plafonds/muren individueel zijn. Montagemateriaal kan worden gekozen al naar gelang het materiaal van plafond/muur.

Raadpleeg een vakspecialist voor de keus van geschikt Montagemateriaal. De installateur moet vaststellen of het plafond/de muur minstens vier keer van het gecombineerde gewicht van scherm/projector en steun kan dragen. **Maximale belasting voor dit product volgens de informatie in deze montagevoorschriften.** Voor de montage moeten ook de installatie- en gebruiksvorschriften voor het te monteren scherm/projector in acht worden genomen.

**ENGLISH**  
**Guarantee terms and conditions**

- SmartMetals Mounting Solutions guarantees that a product that SmartMetals has determined to be defective as a result of deficient manufacture or material this will be repaired or – if necessary – replaced or you will be provided with a replacing part (the previous always to be determined by SmartMetals), without cost, on condition that a claim is made within the period of warranty, which is 5 years.
- In the event of a claim being made under the terms of the warranty, the product needs to be returned to SmartMetals accompanied by a RMA form, which we will send on request. The freight costs back and forth will always be borne by the owner.
- The guarantee provided by SmartMetals shall lapse:
  - if a defect arises as the result of incorrect or inexperienced assembly or installation.
  - in case of improper use or any use not in accordance with the instructions.
  - in case of normal wear and tear.
  - if, without obtaining the written consent of SmartMetals,
  - if, customer or a third party have introduced changes to the product or have attempted to do so, if other items have been attached to the product that should not be attached, if products were processed or revised in some way other than was instructed.
  - if customer or a third party engaged by customer performed repairs without the written consent of SmartMetals beforehand.

**FRANÇAIS**  
**Conditions de garantie**

- SmartMetals Mounting Solutions garantit que tout produit jugé défectueux par SmartMetals du fait d'un vice de fabrication ou de matériaux, sera réparé ou, si nécessaire, remplacé ou vous sera fourni avec une partie remplaçant (la précédente toujours à déterminer par SmartMetals) sans coût supplémentaire, à condition que la réclamation soit faite avant l'expiration de la période de garantie qui est de 5 ans.
- Dans le cas d'une réclamation faite en vertu des termes de la garantie, le produit doit être retourné à SmartMetals accompagnée d'une forme de retour, que nous vous enverrons sur demande. Les frais de transport aller-retour seront toujours à la charge du propriétaire.
- La présente garantie ne s'applique pas lorsque:
  - si un défaut survient à la suite de l'assemblage ou l'installation incorrecte ou inexpérimentée.
  - en cas de mauvaise utilisation ou d'une utilisation non conforme aux instructions.
  - en cas d'usure normale.
  - si, sans avoir obtenu le consentement écrit de SmartMetals, client ou un tiers ont introduit des modifications au produit ou ont tenté de le faire, si d'autres éléments ont été apposés sur le produit qui ne devraient pas être xé, si les produits ont été traités ou révisés d'une autre façon que ce qui était demandé.
  - si le client ou une tierce partie engagée par le client a effectué des réparations sans le consentement écrit de SmartMetals au préalable.



**DEUTSCH**  
**Garantiebedingungen**

- SmartMetals Mounting Solutions garantiert, dass ein Produkt, bei dem SmartMetals Defekte infolge von Fabrikations- oder Materialfehlern feststellt, kostenlos repariert oder, falls notwendig, ersetzt wird, kostenlos repariert oder, falls notwendig, ersetzt wird, kostenlos repariert oder, falls notwendig, ersetzt wird, kostenlos repariert oder, falls notwendig, ersetzt wird.
- Im Falle dass Anspruch unter den Bedingungen der Garantie gemacht wird, muss das Produkt Smart Metals durch eine RMA-Formular, die wir auf Anfrage gerne zusenden, begleitet zurückgegeben werden. Die Frachtgebühren hin und her werden immer vom Besitzer getragen.
- Die Garantie von Smartmetals wird hinfällig:
  - wenn ein Defekt auftritt aufgrund falscher oder unsachgemäßer Montage oder Installation.
  - im Falle einer missbräuchlichen Verwendung oder eine Verwendung nicht den Anweisungen entsprechend.
  - bei normalem Abnutzung.
  - wenn, ohne die schriftliche Zustimmung von Smartmetals, Kunde oder ein Dritter Änderungen am Produkt eingeführt haben oder versucht haben dies zu tun, wenn andere Gegenstände am Produkt befestigt wurden, die nicht befestigt sein sollten, wenn Produkte verarbeitet wurden oder in einigen überarbeitet auf andere Weise als angewiesen wurde.
  - wenn der Kunde oder ein Dritter von ihm beschäftigt Reparaturen ausgeführt hat ohne die schriftliche Zustimmung von Smartmetals vorab.

**NEREDLANDS**  
**Garantievoorwaarden**

- SmartMetals Mounting Solutions garandeert dat in het geval een product dat door SmartMetals ten gevolge van in gebreke gebleven vervaardiging of gebrekkig materiaal als defect wordt beschouwd, deze kosteloos wordt gerepareerd of indien noodzakelijk vervangen of u een vervangend onderdeel toegestuurd krijgt (voorgaande te allen tijde te bepalen door SmartMetals), onder voorwaarde dat de klacht binnen de geldende garantieperiode van 5 jaar wordt ingediend.
- Indien er een beroep op de garantie wordt gedaan, dient het product vergezeld van een RMA formulier, dat u op aanvraag door ons wordt toegestuurd, aan SmartMetals te worden geretourneerd. Vrachtkosten heen en terug komen te allen tijde ten laste van de eigenaar.
- De garantie van SmartMetals komt te vervallen:
  - indien een gebrek is ontstaan als gevolg van, of voortvloeit uit een onjuiste c.q. onoordeelkundige montage of installatie.
  - indien er sprake is van oneigenlijk gebruik of enig gebruik dat niet in overeenstemming is met gebruiksaanwijzingen.
  - indien er sprake is van normale slijtage.
  - indien er zonder schriftelijke toestemming van SmartMetals, opdrachtgever of derden aan het product wijzigingen hebben aangebracht danwel hebben getracht aan te brengen, daaraan andere zaken werden bevestigd die daaraan niet bevestigd dienen te worden, indien deze werden ver- of bewerkt op een andere dan de voorgeschreven wijze.
  - indien opdrachtgever of een door hem ingeschakelde derde een reparatie heeft verricht zonder voorafgaande schriftelijke toestemming van SmartMetals.

SPECIFICATION SHEET

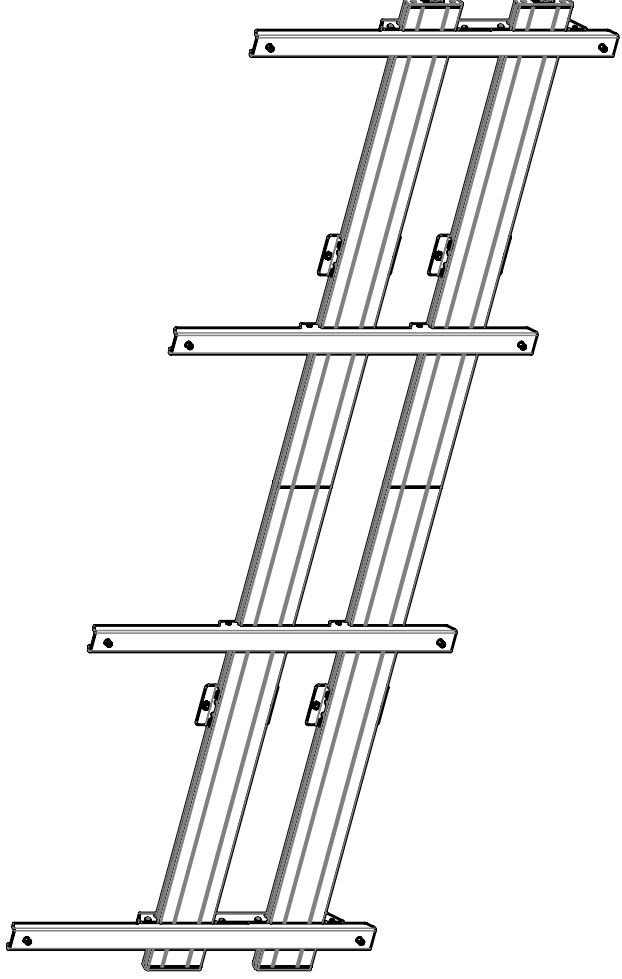

71.50 [2.8]  
12.40 [0.5]

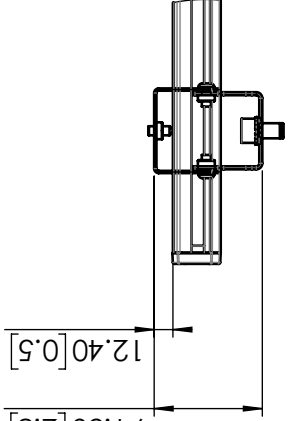

A (1 : 5)

2335 [91.9]

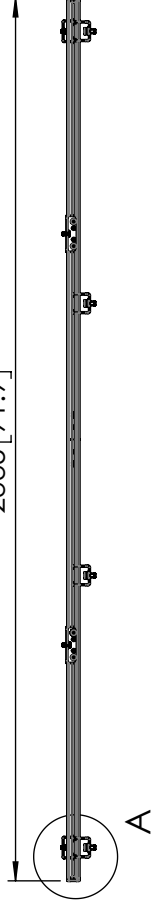

2159 [85.0]

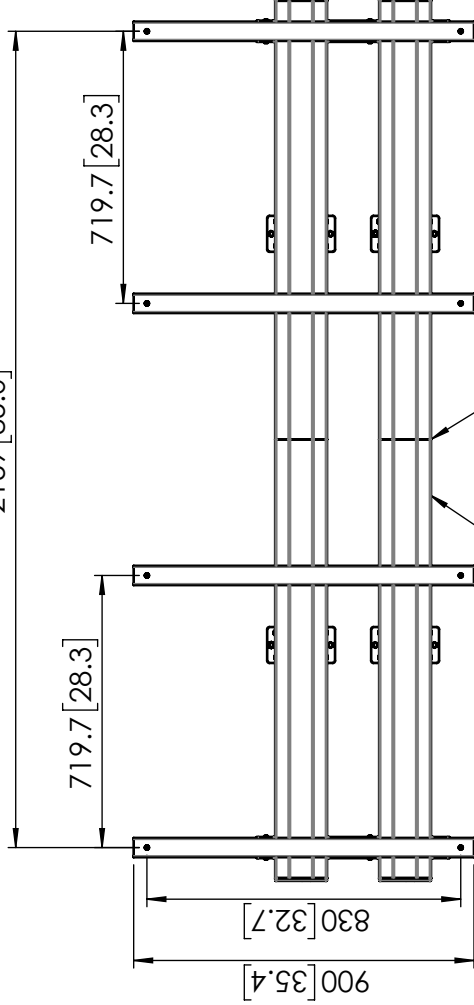

PFB 3411 (x4)

PFA 9104 coupler (x2)

Dimensions	mm	[inch]
Revision	00	
Sheet size	A4	
Projection		
Net weight	24.50 kg	
Gross weight	29.50 kg	
Max. load	kg	
Min. LxWxH	mm	
Max. LxWxH	mm	
VESA	mm	
Max. VESA offset	mm	

Bracket to prevent vertical movement

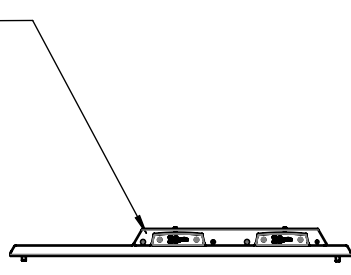

SPECIFICATION SHEET

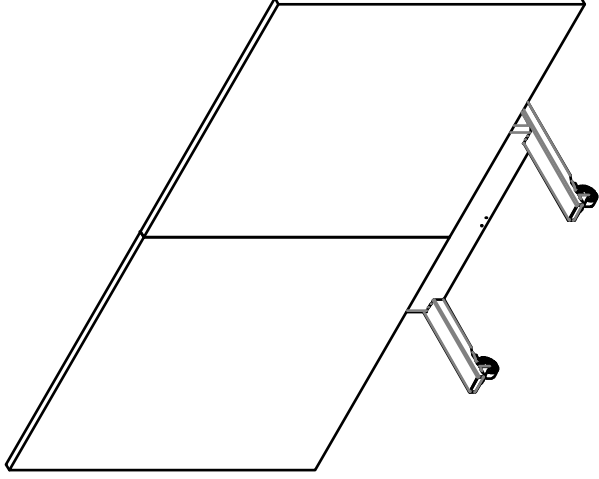

Dimensions	mm	[inch]
Revision	01	
Sheet size	A4	
Projection		
Net weight	140.50 kg	
Gross weight	174.40 kg	
Max. load		kg
Min. LxWxH		mm
Max. LxWxH		mm
VESA		mm
Max. VESA offset		mm

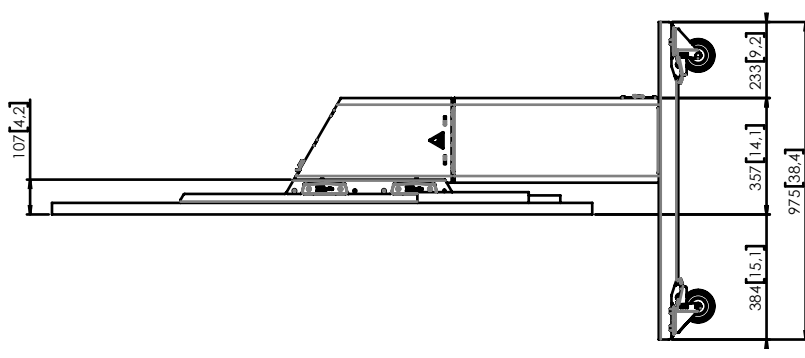
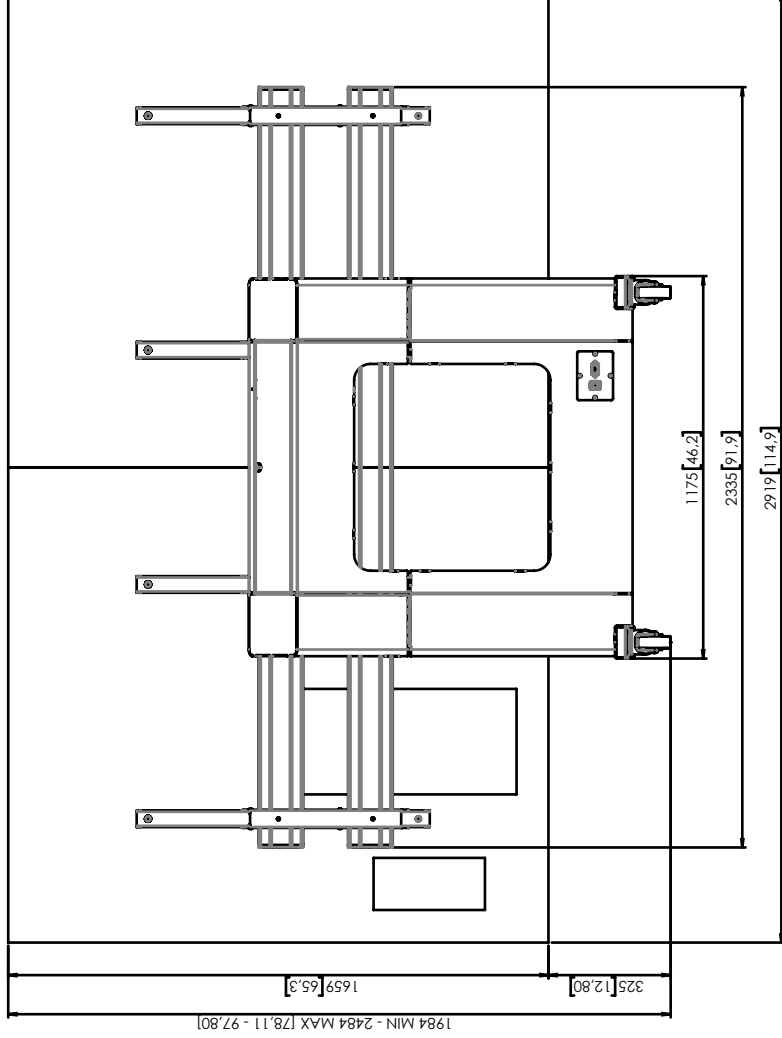

Note: This document and specifications herein are confidential and the exclusive property of SmartMetals Mounting Solutions B.V. Neither this design nor any information contained in this drawing may be reproduced or disclosed to others without written consent of SmartMetals Mounting Solutions B.V. The design and information will not be reproduced, copied or used, either in part or in its entirety, as the basis for the manufacture or sale of items without written permission.

Warning: Please study all instructions and illustrations carefully before installation. Information in this document is subject to change without further notice.